

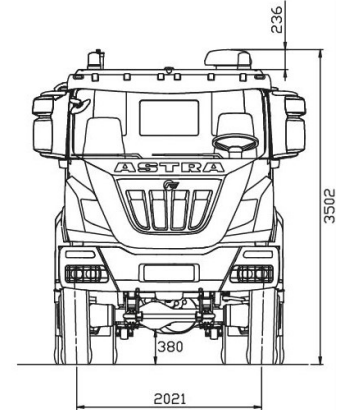

## chassis-cab 8x8 HD88.48

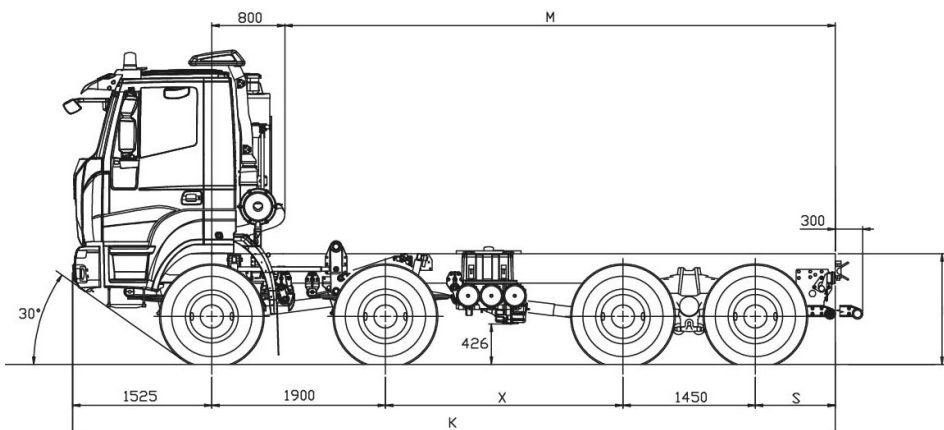

### DIMENSIONS (MM)

X	K	M max(*)	S	H		TURNING DIAMETER (wall to wall)
				unloaded	loaded	
4750	8925	6600	1200	1253	1189	21400
5000	9175	6850	1200	1253	1189	22200
5250	9425	7100	1200	1253	1189	23000
5500	9975	7650	1500	1253	1189	23800
5860	10335	8020	1500	1253	1189	25400

(\*) M max.: indicative value to be confirmed by bodybuilder.  
(Tyres 13R22,5).

### WEIGHTS (KG)

X	Distribution net weight(*)			Max technical weight			
	Front axles	Rear axles	Net Weight	Front axles	Rear axles	Gross Vehicle Weight	Gross Combination Weight
4750	7355	4315	11670	16000 18000 (1) (2)	32000 (2)	50000 (2)	104000
5000	7355	4340	11695				
5250	7355	4360	11715				
5500	7360	4435	11795				
5860	7355	4460	11815				

(\*) Net weight including driver with tanks filled to at least 90%, equipped with standard equipment according to the manufacturer's specifications and, if fitted, the mass of the bodywork, spare wheels and tool box.  
(1) With front axles reinforcing plate (opt 077), tyres on front axles 385/65R22.5 or 325/95R24 and reinforced springs (OPT).  
(2) With front axles reinforcing plate (opt 077), tyres 325/95R24 or max speed limited to 70Km/h depending on tyre type and brand.

Higher speeds are allowed with load reductions subject to Astra technical office approval.  
Other tyres available, subject to Astra technical office approval.





## ENGINES

CURSOR 13 turbo intercooler euro 3 diesel injection/cycle with electronic unit injection pumps. Single block head, four valves per cylinder, light alloy pistons. Total displacement: 12.882 cm<sup>3</sup>. Bore for stroke: 135 x 150 mm. 6 in-line cylinders. Water cooling. Dry air filter with safety cartridge. Vertical muffler.

Max.power(EEC)	354 KW (480 HP) @ 1900 rpm
Max.torque(EEC)	2200 Nm (224 kgm) @ 1000 - 1440 rpm
Turbine	VGT



## GEARBOX

Manual **ZF 16S2520TO** Ecosplit 4 technology gearbox with servoshift, 16 synchronised forward speeds + 2 reverse:

**On request:**

**ZF 16S2320TD - ASTRONIC ZF 16AS2630TO - ALLISON HD4700:** only for wheelbase 3100 mm and 3350 mm.

Gearbox model	Rear axle ratio	Speed [kph] calculated at maximum power rpm																	
		Gears / Gear ratios																	
		1st	2nd	3rd	4th	5th	6th	7th	8th	9th	10th	11th	12th	13th	14th	15th	16th	rev. 1st	rev. 2nd
<b>16AS 2630 TO</b>		14.12	11.68	9.54	7.89	6.52	5.39	4.57	3.78	3.09	2.56	2.09	1.73	1.43	1.18	1	.83	13.07	10.81
<b>Off road slow</b>	<b>5.01</b>	3.43	4.15	5.08	6.15	7.44	9.00	10.61	12.83	15.69	18.94	23.20	28.03	33.91	41.10	48.50	58.43	3.71	4.49
<b>On road fast</b>	<b>5.01</b>	5.50	6.64	8.13	9.83	11.90	14.40	16.98	20.53	25.11	30.31	37.13	44.85	54.26	65.76	77.59	93.49*	5.94	7.18
<b>16S 2520 TO</b>		13.8	11.54	9.49	7.93	6.53	5.46	4.57	3.82	3.02	2.53	2.08	1.74	1.43	1.2	1	.84	12.92	10.8
<b>Off road slow</b>	<b>5.01</b>	3.51	4.20	5.11	6.12	7.43	8.88	10.61	12.70	16.06	19.17	23.32	27.87	33.91	40.41	48.50	57.73	3.75	4.49
<b>On road fast</b>	<b>5.01</b>	5.62	6.72	8.18	9.78	11.88	14.21	16.98	20.31	25.69	30.67	37.30	44.59	54.26	64.66	77.59	92.37*	6.01	7.18

(\*) Max limited speed 90 km/h. Other speeds available, subject to the Astra technical office approval.



## CLUTCH

Single dry plate, diameter 17". Pull type engagement with diaphragm spring. Hydro-pneumatic power steering engagement control, with driven disc wear recovery slave cylinder.

**On request:** Ceramic clutch 17".



## TRANSFER BOX

Mechanical with two ratios. Helical spur gears, mounted on three shafts, engaged with each other. Lockable differential by pneumatic control from driver seat. Air-oil cooler. Transmission ratio 1:1 - 1:1,16. Front/rear torque distribution ratio 1:2,2.



## AXLES

### FRONT

1st and 2nd axle, driving and steering, in cast iron with double reduction, central by bevelled pair, lateral by epicyclic group in wheel hubs. 1st and 2nd axle wheel stud protection.

**On request:**

Lockable differential by pneumatic control from driver seat.

### REAR

Two drive axles in tandem. Double reduction: central with beveled pair, final in the wheel hubs by means of epicycloidal assembly. Torque distribution between the axles by means of a distributor fitted on the intermediate axle. Differential lockable from driver seat. Tandem assembled to the chassis by reaction rods with silentblocks.

**On request:**

Available rear-axle ratio: 1:3.793; 1:4.229; 1:5.009; 1:5.558; 1:6.095; 1:6.588.



## SUSPENSIONS

### FRONT

Parabolic springs, n° 3 leaves 26x90 mm, hydraulic shock absorbers. Standard stabilizer bar on 1st axle.

**On request:**

Stabilizer bar on 2nd axle.

Reinforced parabolic springs, n° 4 leaves 26x90 mm.

### REAR

Parabolic springs, swiveling on central pin: n° 4 leaves 40x100mm, torque bars and stiffening brackets. Standard stabilizer bar on 4th axle.

**On request:**

Stabilizer bar on 3rd axle.

Extra-reinforced conventional springs, n° 10 leaves 25x100 mm.



## CHASSIS

Special steel with high tensile strength limit, two flat and parallel side members (width 820 mm.), C section (320x90x10mm), cross members bolted to the frame.

R.B.M. (Rail Bending Moment): 202.020 Nm (20.593 Kgm.). Steel front bumpers with headlamp protection grids, front maneuvering hook, rear underrun bar, rubber mud-guard 2nd axle, steel fuel tank capacity 300 litres.



## TYRES

**FRONT:** 13R22.5 156/150 G Single tubeless

**REAR:** 13R22,5 156/150 G Twin tubeless

Spare wheel on the chassis.

Other possible combinations:

315/80R22.5 156/150K

385/65R22.5 160J (\*) + 315/80R22.5 156/150K

325/95R24 162/160K (\*)

(\*) Mandatory with 9 ton front axle load.

Other tyres available, subject to the Astra technical office approval.



## BRAKES

Front and rear "duo-duplex" self-adjusting wedge type brakes with automatic play take-up. Total net braking surface 12.368 cm<sup>2</sup>. ABS + EBL system.

**Service brake:** Pedal controlled air brake, acting on all wheels.

**Solo vehicles:** two independent circuits, one for 1st and 2nd axle: one for 3rd and 4th axle; 1st category wheels antilock system. **Towing vehicles:** three independent circuits, one for 1st and 2nd axle, one for 3rd and 4th axle and another for the trailer.

**Emergency brake:** Incorporated in service brake.

**Parking brake:** Mechanical spring-type with pneumatic control acting on 3rd and 4th axle wheels.

**IVECO BRAKE TURBO** engine brake: braking power 300 kW (402 HP).

**On request:**

Hydraulic intarder.



## ELECTRICAL SYSTEM

Voltage: 24 V

Alternator generator 90 A - 28 V (2520 W).

Accumulators: 2 in series, 180 Ah.

Starter motor 24 V 5,5 kW.

Mechanically controlled electrical circuit breaker.



## CAB

Standard white short cab built in galvanized pressed steel with hydraulic tilting up to 60°. Cab suspension with 4 helicoidal springs with coaxial shock absorbers and integrated dampers, anti-roll bar and end-of-stroke pads. Tinted electric door windows. Mechanical rear view mirrors, wide angle mirrors and front view mirror. Internal panels completely washable and fireproof. Compressed air quick coupling for cab cleaning. 4-speed ventilation and heating system with air recirculation system. Air suspended 3-way adjustable driver seat with seat belts. Mechanical passenger seat with seat belts.