

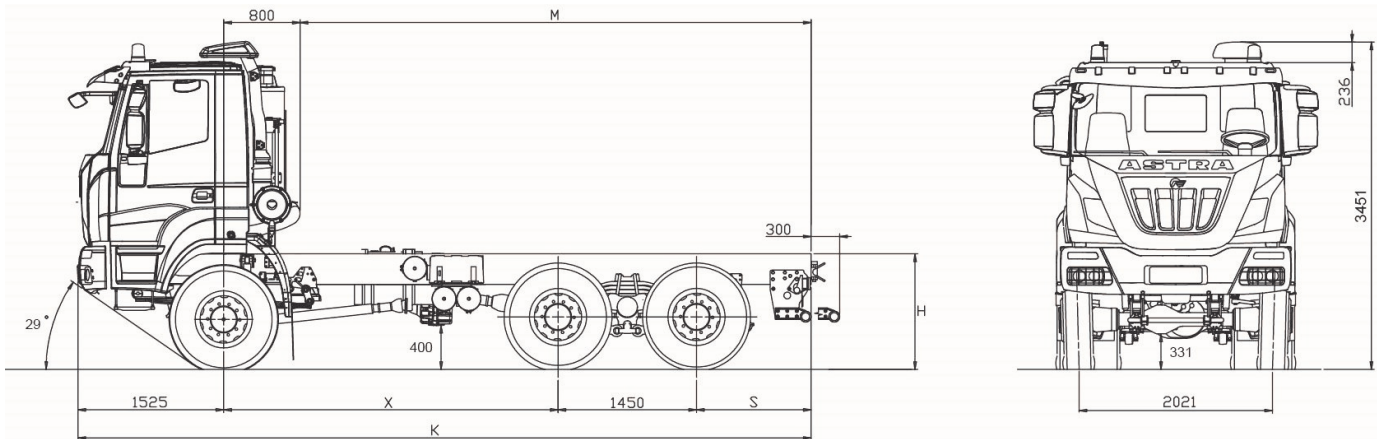

**chassis 6x6
HD66.56**

DIMENSIONS (MM)

| X | K | M max(*) | S | H | | TURNING DIAMETER (wall to wall) |
|------|------|----------|------|----------|--------|------------------------------------|
| | | | | unloaded | loaded | |
| 3500 | 7675 | 5350 | 1200 | 1204 | 1141 | 17400 |
| 3800 | 7975 | 5650 | 1200 | 1204 | 1141 | 18300 |
| 4100 | 8275 | 5950 | 1200 | 1204 | 1141 | 19300 |
| 4500 | 8675 | 6350 | 1200 | 1204 | 1141 | 20600 |

(*) M max.: indicative value to be confirmed by bodybuilder.
(Tyres 13R22.5)

WEIGHTS (KG)

| X | Distribution net weight(*) | | | Max technical weight | | | |
|------|----------------------------|------------|------------|-------------------------------|------------|----------------------|--------------------------|
| | First axle | Rear axles | Net Weight | First axle | Rear axles | Gross Vehicle Weight | Gross Combination Weight |
| 3500 | 5495 | 4965 | 10460 | 8000 9000 (1) 10000 (2) | 32000 (3) | 40000 (3) | 104000 |
| 3800 | 5540 | 4955 | 10495 | | | | |
| 4100 | 5580 | 4940 | 10520 | | | | |
| 4500 | 5640 | 4940 | 10580 | | | | |

(*) Net weight including driver with tanks filled to at least 90%, equipped with standard equipment according to the manufacturer's specifications and, if fitted, the mass of the bodywork, spare wheels and tool box.

(1) With tyres on front axles 385/65R22.5 or 325/95R24 and reinforced springs (OPT).

(2) With Kessler front axle, reinforced suspension and steering system and max speed limited to 70 km/h, depending on pneus type and brand.

(3) With tyres 325/95R24 or max speed limited to 70 Km/h depending on pneus type and brand.

Higher speeds are allowed with load reductions subject to Astra technical office approval.

Other tyres available, subject to Astra technical office approval.



ENGINES

CURSOR 13 turbo intercooler diesel injection/cycle with electronic unit injection pumps. 6 in-line cylinders. Single block head, four valves per cylinder, light alloy pistons. Total displacement: 12.882 cm³. Bore for stroke: 135 x 150 mm. Water cooling. Dry air filter with safety cartridge. Vertical muffler. Emissions according to Euro 5 regulation norms SCR (Selective Catalytic Reduction) system composed of catalytic muffler, AdBlue-tank, injection and control system.

Max.power(EEC) 412 KW (560 HP) @ 1900 rpm
 Max.torque(EEC) 2500 Nm (255 kgm) @ 1000 - 1690 rpm
 Turbine VGT(Variable Geometry Turbocharger)



GEARBOX

Manual **ZF 16S2520TO** Ecosplit 4 technology gearbox with servoshift, 16 synchronised forward speeds + 2 reverse:
On request: ASTRONIC ZFI6AS2630 TO - ALLISON HD4700 (wheelbase ≥4100mm).

| | | Speed [kph] calculated at maximum power rpm | | | | | | | | | | | | | | | | | |
|----------------------|-----------------|---|-------|------|-------|-------|-------|-------|-------|-------|-------|-------|-------|-------|-------|-------|---------|----------|----------|
| | | Gears / Gear ratios | | | | | | | | | | | | | | | | | |
| Gearbox model | Rear axle ratio | 1st | 2nd | 3rd | 4th | 5th | 6th | 7th | 8th | 9th | 10th | 11th | 12th | 13th | 14th | 15th | 16th | rev. 1st | rev. 2nd |
| 16AS 2630 TO | | 14.12 | 11.68 | 9.54 | 7.89 | 6.52 | 5.39 | 4.57 | 3.78 | 3.09 | 2.56 | 2.09 | 1.73 | 1.43 | 1.18 | 1 | .83 | 13.07 | 10.81 |
| Off road slow | 5.01 | 3.93 | 4.75 | 5.81 | 7.02 | 8.50 | 10.28 | 12.13 | 14.66 | 17.94 | 21.65 | 26.52 | 32.04 | 38.76 | 46.97 | 55.42 | 66.78 | 4.24 | 5.13 |
| On road fast | 5.01 | 6.04 | 7.30 | 8.94 | 10.81 | 13.08 | 15.82 | 18.66 | 22.56 | 27.59 | 33.31 | 40.80 | 49.29 | 59.63 | 72.26 | 85.27 | 102.73* | 6.52 | 7.89 |
| 16S 2520 TO | | 13.8 | 11.54 | 9.49 | 7.93 | 6.53 | 5.46 | 4.57 | 3.82 | 3.02 | 2.53 | 2.08 | 1.74 | 1.43 | 1.2 | 1 | .84 | 12.92 | 10.8 |
| Off road slow | 5.01 | 4.02 | 4.80 | 5.84 | 6.99 | 8.49 | 10.15 | 12.13 | 14.51 | 18.35 | 21.91 | 26.65 | 31.85 | 38.76 | 46.19 | 55.42 | 65.98 | 4.29 | 5.13 |
| On road fast | 5.01 | 6.18 | 7.39 | 8.98 | 10.75 | 13.06 | 15.62 | 18.66 | 22.32 | 28.23 | 33.70 | 40.99 | 49.00 | 59.63 | 71.06 | 85.27 | 101.51* | 6.60 | 7.90 |

(*) Max limited speed 90 km/h. Other speeds available, subject to the Astra technical office approval.



CLUTCH

Single dry plate, diameter 17". Pull type engagement with diaphragm spring. Hydro-pneumatic power steering engagement control, with driven disk wear recovery slave cylinder.

On request: Ceramic clutch 17".



TRANSFER BOX

Mechanical with two ratios. Helical spur gears, mounted on three propeller shafts, engaged with each other. Lockable differential by pneumatic control from driver seat. Transmission ratio 1:0,913 - 1:1,407. Front/rear torque distribution ratio 1:2,6.



AXLES

FRONT

1st axle, driving and steering, in cast iron with double reduction, central by bevelled pair, lateral by epicyclic group in wheel hubs.

On request:

Lockable differential by pneumatic control from driver seat.
 Reinforced front axle max technical weight up to 9 ton with reinforced suspension and up to 10 ton with reinforced suspension and steering system.

Available axle ratio: 5,01 - 5,47 - 5,96 - 6,28.

REAR

Two drive axles in tandem. Double reduction: central with beveled pair, final in the wheel hubs by means of epicycloidal assembly. Torque distribution between the axles by means of a distributor fitted on the intermediate axle. Differential lockable from driver seat. Tandem assembled to the chassis by reaction rods with silentblocks.

On request: Rear-axle ratio 1:3.793 -1:4.229 -1:5.009 -1:5.558 -1:6.095 -1:6.588.



SUSPENSIONS

FRONT

1st axle, parabolic springs, n° 4 leaves 24x90 mm, with hydraulic shock absorbers. Standard stabilizer bar.

On request:

Reinforced parabolic springs, n° 5 leaves 24x90 mm.

REAR

Parabolic springs, swivelling on central pin: n° 4 leaves 40x100 mm.

On request:

Stabiliser bar on 2nd axle.

Stabiliser bar on 3rd axle.

Extra-reinforced conventional springs, n° 10 leaves 25x100 mm.



CHASSIS

Special steel with high tensile strength limit, two flat and parallel side members (width 820 mm.), C section (320x90x10mm), cross members bolted to the frame. R.B.M. (Rail Bending Moment): 202.020 Nm (20.593 Kgm.). Steel front bumpers

Characteristics and equipment are subject to changes without prior notice

Technical data and general specifications - validity to be checked according to each individual configuration

with headlamp protection grids, front manoeuvring hook, rear underrun bar, steel fuel tank capacity 300 litres.



TYRES

FRONT: 13R22,5 156/150 G Single tubeless

REAR: 13R22,5 156/150 G Twin tubeless

Spare wheel on the chassis.

Other possible combinations:

315/80R22.5 156/150K

385/65R22.5 160J (*) + 315/80R22.5 156/150K

325/95R24 162/160K (*) (**)

(*) Mandatory with 9 ton front axle load.

(**) Mandatory with 10 ton front axle load.

Other tyres available, subject to the Astra technical office approval.



BRAKES

Front and rear "duo-duplex" self-adjusting wedge type brakes with automatic play take-up. Total net braking surface 9.276 cm². ABS + EBL system.

Service brake: Pedal controlled air brake, acting on all wheels. Solo vehicles: two independent circuits, one for 1st axle, one for 2nd and 3rd axle. Towing vehicles: three independent circuits, one for 1st axle, one for 2nd and 3rd axle and another for the trailer.

Emergency brake: Incorporated in service brake.

Parking brake: Mechanical spring-type with pneumatic control acting on 2nd and 3rd axle wheels.

IVECO BRAKE TURBO engine brake: braking power 255 kW (347 HP).

On request: Hydraulic Intarder.

1st axle immobiliser system.

OFF/ROAD button for excluding ABS for speed 15 kph.



ELECTRICAL SYSTEM

Voltage: 24 V

Alternator generator 90 A - 28 V (2520 W).

Accumulators: 2 in series, 180 Ah.

Starter motor 24 V 5,5 kW.

Mechanically controlled electrical circuit breaker.



CAB

Standard white short cab built in galvanized pressed steel with hydraulic tilting up to 60°. Cab suspension with 4 helicoidal springs with coaxial shock absorbers and integrated dampers, anti-roll bar and end-of-stroke pads. Tinted electric door windows. Mechanical rear view mirrors, wide angle mirrors and front view mirror. Internal panels completely washable and fireproof. Compressed air quick coupling for cab cleaning. 4-speed ventilation and heating system with air recirculation system. Air suspended 3-way adjustable driver seat with seat belts. Mechanical passenger seat with seat belts.